



PRINT ENTRIES

CROPPED IMAGE ©ADELE KRANTZ

PRINT ENTRIES

Important Information

- » When you upload your image to the entry portal, it should reflect the image that will be judged.
- » New Zealand print entries will automatically go through to live judging. Australian and International print entries must first go through a digital pre-judging round.
- » You can still receive an award if your image does not go to live judging, provided it scores within the award range.
- » Merit points can still be earned on images that do not go through to live judging (NZIPP Affiliate, Accredited and reciprocal rights organisation entrants only) provided it scores within award range.
- » It is recommended when printing that you view and check your prints under similar lighting conditions to those at print judging. The judges' lighting will be tested with a light meter set at 100ISO with the reading taken from the centre point of the print and the light meter pointing toward the viewing position of the judges. The exposure reading will be 1/30th of a second at f2.8. The ambient room lighting will be approximately 2 stops less.
- » Each judging room has a large TV for the audience to see the image. The TV's are not viewed by the judges - they can only see the physical print. It is important to know this, because the live stream that is published comes from the TV and is not reflective of what the judges are viewing.
- » The visible portion of an image, inside any matting, must be no smaller than 25cm on the longest side. One side of the image must be at least 25cm. The only exceptions to this are:
 - » When entering Polaroid, tin type or glass plate originals;
 - » The Expressive Category.We recommend you print your image bigger to ensure you meet the minimum size.
- » Prints should have the PDF print-out attached to the back of the print for identification purposes.
- » Prints should be sent using sturdy packaging.
- » It is a requirement for all entries that you send your original files containing All 'original capture' (RAW, DNG, or unedited JPEG) for each and every element used within each entry submitted and the final image file for each entry. This allows the Honours Council to have information on hand at the event should an issue arise. Failure to supply these files by the specified time-frame may result in disqualification.
- » We encourage all entrants to come to Nelson and watch the live judging in-person. This is a great learning opportunity for everyone. Live judging takes place from Thursday 11th - Saturday 13th August 2022, and is followed by the New Zealand Photography Show Conference and Gala Dinner event.

USEFUL CONTACTS

FOR PURCHASE OF PRINT PACKAGING:

Rigid Print Cases (Plastic - last 5-10 years or more - \$95 plus GST and p&h): Chris Parker: chris@photographics.co.nz
Carboard Print Boxes (last 1-2 years - \$12 plus GST and p&h): Sean Dick: sean@evokestudio.co.nz

NZIPP SPONSORS AND SUPPORTERS WHO OFFER PROFESSIONAL PRINTING AND MOUNTING OF PRINTS FOR AWARDS:

Chris Helliwell (Edges Art and Framing): frameit@edgesworkshop.co.nz
Sean Dick (Evoke Studio): sean@evokestudio.co.nz

PREPARING PRINT ENTRIES

SQUARE & CIRCLE IMAGES

- » The width or diameter of the visible portion of the image must be no smaller than 25cm.

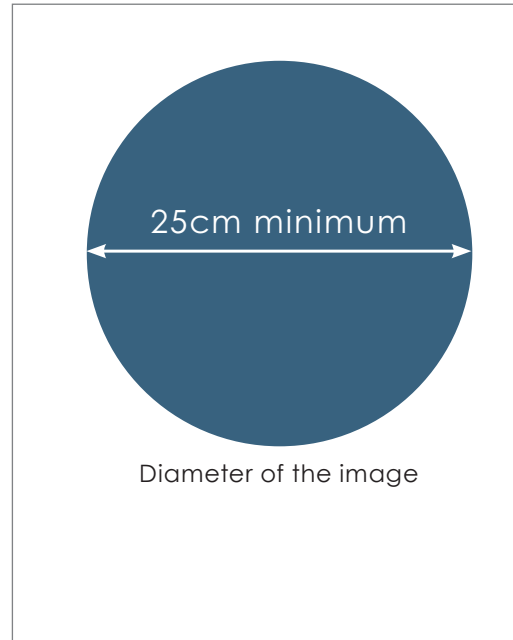
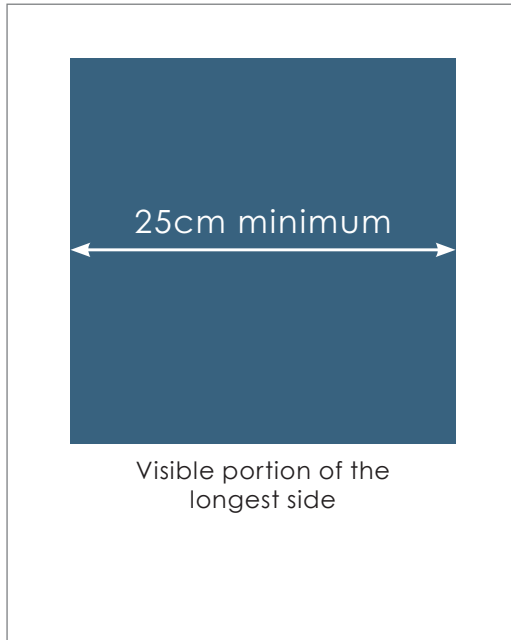

MULTIPLE IMAGES (SERIES)

For an entry made up of two or more images on a single mount:

- » The height of at least one image must be at least 25cm; or,
- » The combined width of all images, the visible portion only, must be at least 25cm. This excludes the spacing between the images.

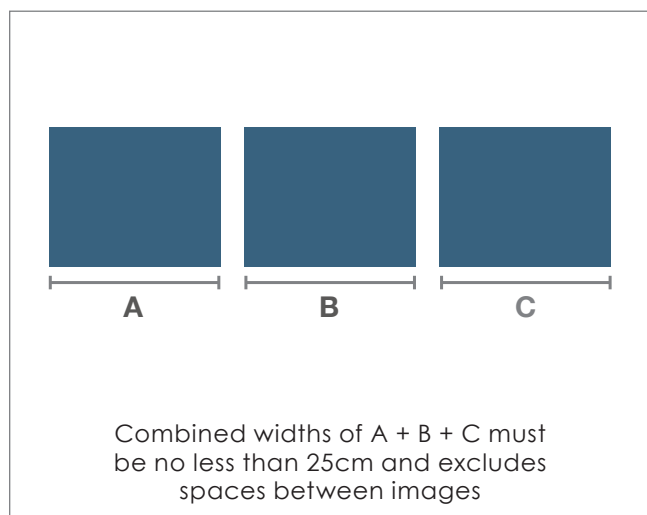
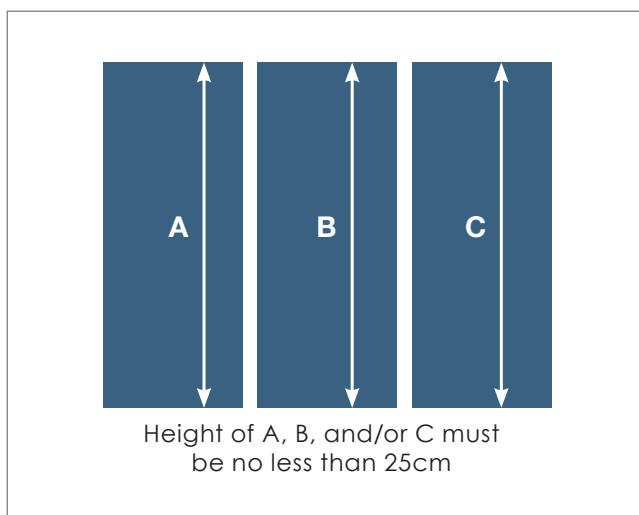

PRINT LABELS

PDF IDENTITY LABELS

PDF documents are generated on completion of your online entry registration. Save these documents to your computer. Once you have made payment and submitted your entry, you'll see the PDF icon to the right of your entry. Click on this to download and save these documents to your computer.

ID	Entry	Chapter	Category	Status	Updated
3134	CR_PRINT_Bloggs_Joe_01	Default	TEST	In progress	23 hours ago

PDFs

- » These are two page documents. We need the barcode, entry details and file name from the document, You can cut and paste these to make them fit on the back of your print. We apologise that we are unable to alter the way these print.
- » Do not reduce the size of the pdf when printing
- » They must be clear and black to ensure they can be read by the scanners,
- » Attach the PDF printout to the top left on the back of each respective print.
- » Write the word 'TOP' to show the correct viewing orientation.
- » Remove residue glue, adhesive tape, velcro, etc., from the back of mounted work, to prevent damage to your own prints or to the work of others.

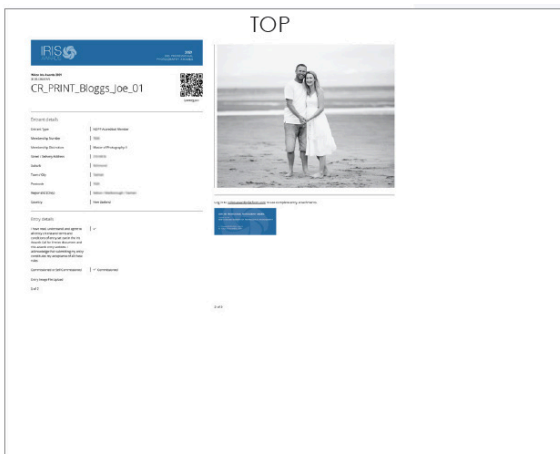

MOUNTING PRINT ENTRIES

MOUNTING YOUR PRINTS

The presentation of entries in the Iris Awards must be of a professional standard. They also need to be lightweight and of a uniform size for ease of handling and display.

For all print entries, (excluding the Expressive Category):

- » These must be flush or window-mounted onto a 3mm or 5mm foam core backing board; total thickness must be between 3-7mm
- » The matt board and backing board dimensions must be 50cm x 40cm.
- » The prints can be mounted using either a vertical or horizontal orientation.
- » The largest size a print can be is 50cm x 40cm
- » Prints must be mounted in such a way they will not damage other prints or require special handling - no part is to protrude above the surface level of the matt board.

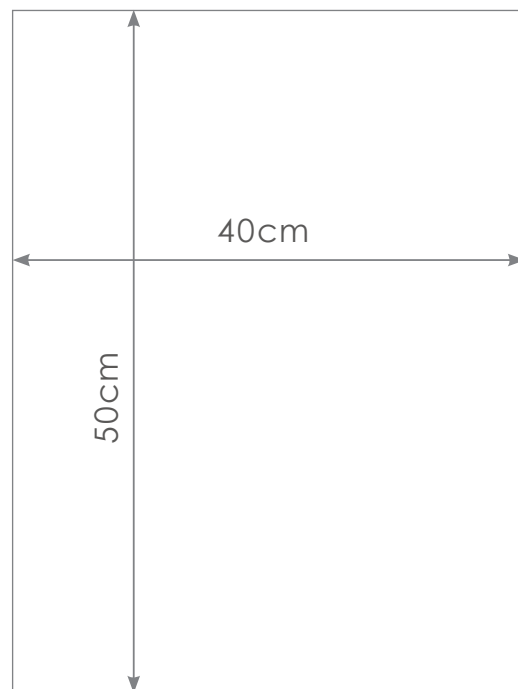
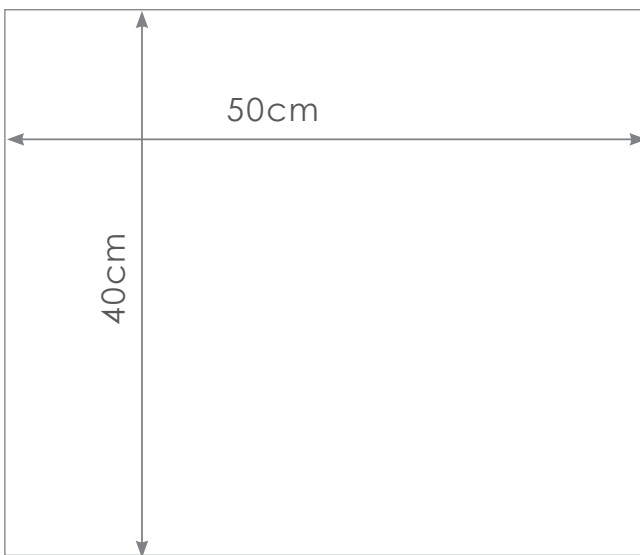

LIGHTING

It is recommended when printing that you view and check your prints under similar lighting conditions to those at print judging. The judges lighting will be tested with a light meter set at 100ISO with the reading taken from the centre point of the print and the light meter pointing toward the viewing position of the judges.

The exposure reading will be 1/30th of a second at f2.8. The ambient room lighting will be approximately 2 stops less.

PACKAGING PRINTS

PACKING YOUR PRINTS

When packing your prints:

- » Interleaf your prints with a sheet of tissue paper, or similar, to protect the print surface. There is no need to 'wrap' and secure each individual print. This creates excess rubbish.

Include with your entries:

- » USB (if not uploading original files via dropbox transfer); containing all original capture (RAW, DNG or unedited JPEG) files
- » Return address label containing your name, address and phone number to be attached to the outside of your package when we return it to you.

INDIVIDUAL ENTRANTS (INCLUDING INDIVIDUAL STUDENT ENTRIES)

Entering the Iris Awards can be a big financial commitment, so we are offering two options for the submission and return of standard print entries:

1. Print case (rigid plastic)
2. Print box (cardboard)

If you already own one, a print case is still the preferred option to better protect your prints and for handling logistics.

Please note, no two entrants can share a print case or print box, even if from the same studio. The only exception is student entries. See the bottom of this page for more details.

Print case - this is a rigid plastic case which holds up to 10 matted prints and will last for years. Many are still using the same case they purchased 20+ years ago!

- » Order your print case well in advance by contacting Chris Parker at chris@photographics.co.nz
- » The print box will be sent direct to you so you can use it for sending in your entries.

Print box - this is a sturdy cardboard box (520mm L x 440mm W x 75mm D) and will fit up to 10 matted prints. A print box will cost \$12 plus p&h and may last a year or two.

- » Order your print box well in advance by contacting Sean at sean@evokestudio.co.nz.
- » The print box will be sent direct to you so you can use it for sending in your entries.
- » Tape the print box carefully so it doesn't come open in transit.
- » Firmly attach a sheet of acetate (one side of a clear acetate L-pocket is great for this) to the box. Insert your address label into this. Adding a velcro dot at the open edge of the pocket will prevent the label falling out.
- » Your entries will be returned in the same print box.

Print cases or boxes must be no bigger than 55cm x 45cm and 10cm deep. If you are not using a print case or box as described above, you must use a box packaging that does not require taping and/ or wrapping of prints for their return. It must be sturdy to protect your images. NZIPP takes no responsibility for prints damaged in transit.

STUDENT ENTRIES ONLY

Individual students from the same institution can share a print case or sturdy returnable box.

The Institution won't be charged a handling fee, however when sending **you must include a pre-paid return 'NZ Courier' ticket to cover the cost to return it to you.** Should entries boxes/cases arrive without return courier ticket(s) they are unable to be sent back.

SENDING PRINTS

To avoid delays, worry, and disappointment:

- » Send your entries well in advance of the print delivery deadline, especially due to Covid delays!
- » Take into account any delays that may be caused by your courier or postal service for overseas entries
- » Track your entries!

****Note:** You need to pay the cost to deliver your prints to Nelson. Your handling fee includes the return of your print case (excluding Student bulk entry). Print cases can be collected from Nelson from Monday 15th August 2022 if you wish to take it home with you - however no portion of handling fee will be refunded.

AUSTRALIAN AND OTHER INTERNATIONAL ENTRANTS

Print cases need to pass through NZ Customs. To make the process smooth, and to minimise the risk of additional fees and taxes:

- » Mark your Customs Declaration form with the following:
Entries into the NZ Iris Professional Photography Awards
Delivery deadline: 5:00pm (NZST), Monday, 8th August 2022
Items returned to sender after judging
- » Limit the monetary value of the goods to no more than \$150.00;
- » Track your print case progress to the delivery address on the label.

NZIPP will not be responsible for paying any import duties or GST for entries. Nor will NZIPP take responsibility for coordinating the release of an entrant's work from Customs or their agent.

Entries must be accompanied with return address packaging and any international documentation that may be required if you want the entry returned. We suggest using the courier companies DHL or TNT to send your prints.

DELIVERY CONCERNS

If your print case has not arrived by the delivery deadline, 5:00pm (NZST), Monday, 8th August 2022, please notify us immediately at honours@nzipp.org.nz

SEND PRINT ENTRIES AND USBS (IF USED) TO:

NZIPP IRIS AWARDS
C/- 210 HILL STREET
RICHMOND 7020
TASMAN
NEW ZEALAND

ENTRY CHECKLIST

When you are ready:

1. Prepare your files for online entry before the closing deadline:

Australian and International entries must be received by 11:59pm (NZST), Sunday, 29th May 2022

New Zealand entries must be received by 11:59 pm (NZST), Sunday, 26th June 2022

2. Enter online at <https://nzipp.awardsplatform.com/>. You can go back in and enter more images until the closing date, but you can't change an entry once you've submitted it. New Zealand print entries automatically go through to live judging. Australian and International print entries must first go through a pre-judging round. Once the Australian and International pre-judging round is complete, we will invite the top scoring entrants to submit prints for live judging.

3. If you have been invited to enter prints, make sure you have ordered a print case to send them in.

4. Prepare your prints. Follow the instructions to print and mount your images. It can be helpful to print this section and give it to your printer and/or framer to ensure your images meet the criteria outlined.

5. Attach the PDF documents to the back of your prints.

6. Prepare your files for vetting.

You can upload your files to our Dropbox transfer link, or send them on a USB. We suggest that those creating composites or images with multiple layers, send a USB.

You need to submit:

- » All 'original capture' (RAW, DNG, or unedited JPEG) files for each and every element used within each entry submitted;
- » The final image file for each entry. This is the same flattened JPEG file you will upload as part of your online entry registration.

Prepare a folder:

- » Create a single main folder with your name
- » Inside the main folder, create a separate folder for each image entered, naming it with a short image title that allows for quick identification of each entry.

7. Upload your folder to our Dropbox Transfer Link. You don't need to have a Dropbox subscription to upload these files. Go to: <https://www.dropbox.com/request/uAEV9hK2T3LXM26ioHVQ> - choose "Add files" - choose "Folders from Computer" and select the Single Main Folder with your name that you created above, to upload all of the folders and files in one batch. Dropbox transfers must be completed by 5.00pm (NZST) Monday, 8th August 2022.

OR

Put your images onto a USB and send to :

NZIPP Iris Awards
c/- 210 Hill Street
Richmond
Tasman 7020
NEW ZEALAND

8. Package your entries for sending and include your USB of files for vetting (or upload your files as per instructions above).

9. Send your print case to arrive before the delivery deadline, 5.00pm (NZST) Monday 8th August 2022.

PRINT ENTRY CHECKLIST

1

PREPARE FILES FOR ENTRY

2

ENTER ONLINE

3

ORDER A PRINT CASE IF YOU
DON'T HAVE ONE ALREADY

4

PREPARE YOUR PRINTS

5

ATTACH PDF DOCUMENTS TO THE
BACK OF PRINTS

6

PREPARE YOUR VETTING FILES

7

UPLOAD VETTING FILES, OR PUT
THEM ONTO A USB

8

PACKAGE ENTRIES AND ADD USB
IF YOU ARE SENDING ONE. DON'T
FORGET A RETURN
ADDRESS LABEL

9

SEND YOUR PRINT CASE TO
ARRIVE BEFORE THE DEADLINE,
5:00PM (NZST), MONDAY, 8TH
AUGUST 2022